

Extremely Serviceable

Fewer parts ... faster servicing. No special tools or equipment required.



- 5-minute packing change



- 15-minute pop-out valve cartridge change

Remarkably Versatile

Tackle varied applications in less time with one convertible system



- On-site pressure conversion
- Slip-fit stuffing boxes
- Simple bolt-on conversion fluid ends

The UNx™ Fluid End X-treme Advantage

Unmatched for performance and flexibility!

Contractors who live and breathe waterblasting performance demand the superior durability and flexibility of the UNx fluid end system. For ease of maintenance, in-the-field versatility, or overall operating efficiency, nothing beats the UNx system.

Engineered components streamline routine maintenance. Even operating pressures can be changed in minutes — from 5,000 to 40,000 PSI — with the UNx interchangeable fluid end design.

Now you've got the flexibility to tackle all jobs, the efficiency to keep operating costs low, and the superior performance to optimize productivity hour after hour, day after day.

Fewer Parts, Fewer Problems



Simple & Dependable

Uni-Valve Cartridge

- self-contained suction and discharge valve assembly
- slip-fit for easy maintenance
- in-line design minimizes turbulence

Swing-Down Manifold

- easy access to valves
- weep holes indicate source of seal leaks

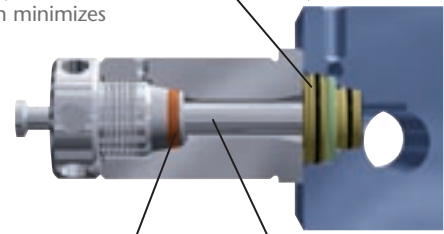

Uni-Pak™ Plunger Packing Set

- one-piece packing
- tapered for easy removal
- water lubricated — no oil

Clamp-Style Plungers

- specifically designed for the rigors associated with each operating pressure
- clamp-on design for easy maintenance



X-Series diesel waterblast systems are available in both skid and trailer configurations. For unusual applications or configurations, Jetstream can offer custom solutions to meet your exact needs.

X-Series Diesel Specifications

Series	HP	Pressure (psi)	Flow (gpm)							
			6,000	7,500	10,000	12,500	15,000	20,000	30,000	36,000
X3000 Series	110 HP	Pressure (psi)	6,000	7,500	10,000	12,500	15,000	20,000	30,000	36,000
		Plunger Size (no.)	11	10	9	8	7	6	—	5
		Flow (gpm)	23.2	18.4	14.9	11.8	9.9	7.4	—	4.7
X3600 Series	150 HP	Pressure (psi)	6,000	7,500	10,000	12,500	15,000	20,000	30,000	36,000
		Plunger Size (no.)	—	11	10	9	8	7	—	5
		Flow (gpm)	—	23.3	18.4	14.9	11.8	9.7	—	5.2
X4200 Series	170 HP	Pressure (psi)	5,000	7,500	10,000	12,500	15,000	20,000	30,000	40,000
		Plunger Size (no.)	15	13	11	10	9	8	—	—
		Flow (gpm)	45.4	31.2	23.2	18.6	15.7	11.7	—	—
X4200 Series	215 HP	Pressure (psi)	6,000	7,500	10,000	12,500	15,000	20,000	30,000	40,000
		Plunger Size (no.)	15	13	12	11	10	9	7	6
		Flow (gpm)	50.3	39.8	32.2	27.0	21.5	17.0	10.0	8.0
X4200 Series	250 HP	Pressure (psi)	6,000	8,000	10,000	12,500	15,000	20,000	30,000	40,000
		Plunger Size (no.)	16	15	13	12	11	10	8	7
		Flow (gpm)	62.1	48.6	38.7	31.3	26.3	19.4	11.9	9.7
X4200 Series	325 HP	Pressure (psi)	6,000	8,000	10,000	12,500	15,000	20,000	30,000	40,000
		Plunger Size (no.)	—	16	15	13	12	11	—	8
		Flow (gpm)	—	62.1	50.1	39.7	32.0	25.1	—	11.9

Your Waterblast Solutions Provider



Electric

Ideal for waterblast applications within process plants, industrial operations and military environments. Available as stationary skids or steerable in-plant trailers.



5000Q

The most versatile and cost effective 500 horsepower waterblast system available.



Compact design diesel waterblast systems are engineered to meet stringent, European equipment requirements. Available from 125 to 300 horsepower with footprints as small as 4' x 7'.



Offshore Skids

With a host of unique features, these machines are certified to perform to the rigorous offshore standards



Containerized advanced waterjetting systems combine an innovative pump with advanced controls and a host of engineered features.

The RightStart program provides personal training with the purchase of your new waterblaster. Classroom and hands-on instruction by a RightStart technician helps your operators learn to use your new equipment with optimum efficiency and safety right from the start.



For best assistance, contact Jetstream of Houston or your Regional Sales Manager to determine how to best serve your needs.

FS Solutions Ohio Service Center
1144 Expressway Dr. – South Toledo, OH 43608
PH: 888-415-RENT (7368)

FS Solutions Texas Service Center
2500 E. Pasadena Frwy Pasadena, TX 77506
PH: 713-472-1529

FS Solutions Alabama Service Center
8584 Borden Ave. Leeds, AL 35094
PH: 800-822-8785

FS Solutions California Service Center
1510 Hayes Ave. Long Beach, CA 90813
PH: 866-515-9891

FS Solutions Louisiana Service Center
3111 S. Darla Ave. Gonzales, LA 70737
PH: 225-647-0660

Jetstream of Houston, LLP

5905 Thomas Rd. • Houston, TX 77041
Phone: (832) 590-1300 • Fax: (832) 590-1304 • Toll Free: (800) 231-8192

www.waterblast.com

Copyright Jetstream of Houston, LLP ©2009

Catalog 20044
P/N J70394
Effective 8/2009

Jetstream Diesel Waterblast Units – The Contractor's Choice



The X-treme Duty Line of Waterblasting Systems

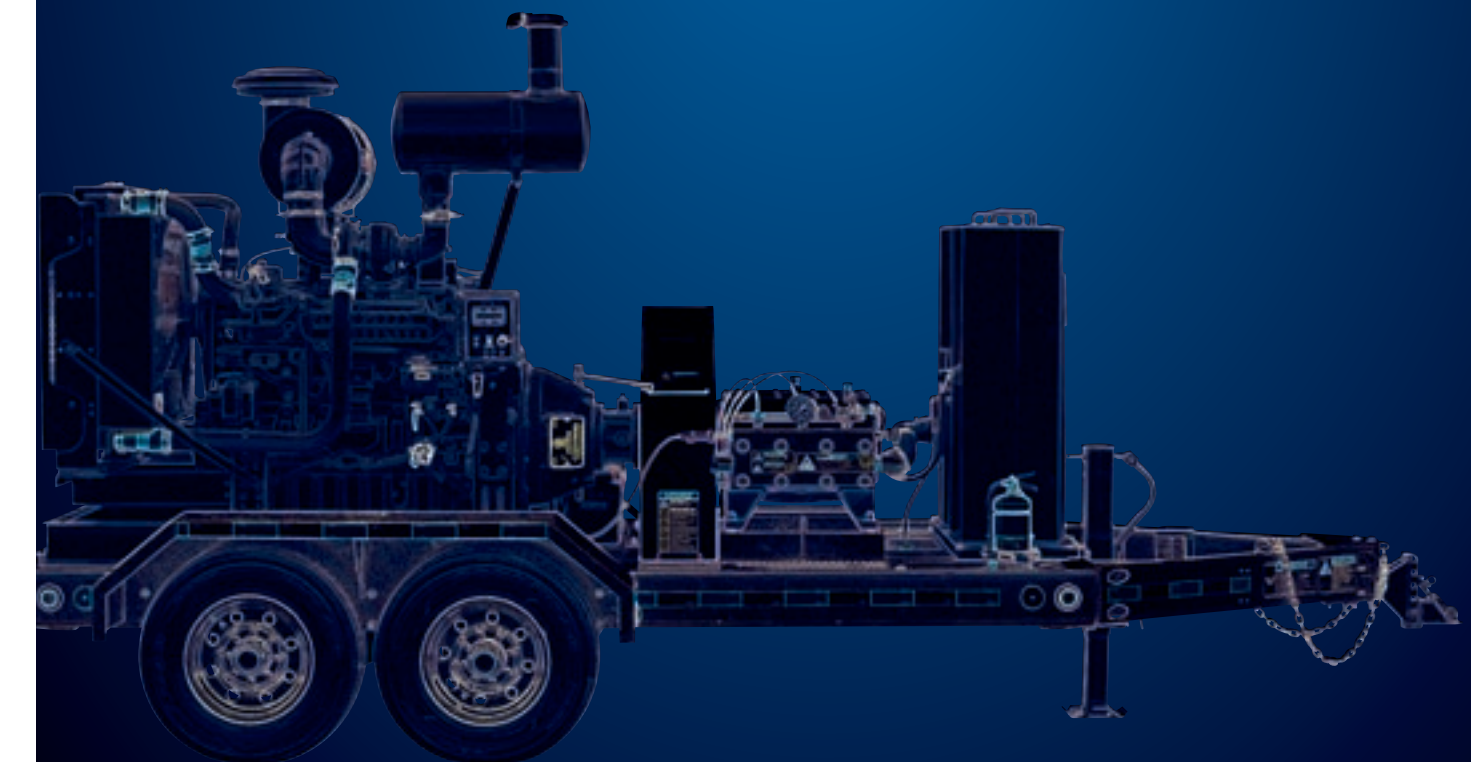

The X-Series waterblasting systems from Jetstream are engineered to outperform and outlast any other unit of its kind.

What happens when Jetstream takes the toughest waterblasting system in the industry and improves it from end to end? You get an X-treme duty unit with enhanced performance ... superior durability ... and unsurpassed operating efficiency. Welcome to Jetstream's X-Series waterblasting systems.

The X-Series represents the best of the best in waterblast equipment.

The X-Series units deliver a host of engineered improvements. One of the most notable changes is the new Guardian™ water tank and filter system. The Guardian's integrated design helps extend system life, while larger filters help extend on-site operating time.

Like all Jetstream waterblast systems, the X-Series is built around the UNx™ Pump: the most efficient, easy-to-use, and versatile waterblast pump available.

You still have a choice of skid or trailer mounted units. And you still have Jetstream's exceptional customer service team and service facilities to support you day and night.

We invite you to explore all the enhancements and operating features of the Jetstream X-Series. Together, they can take your waterblasting operations to an X-treme level of performance and operating efficiency.



High-Performance Diesel Engines

- choice of John Deere, Cummins or Caterpillar
- open power unit keeps engine cooler and provides easy access for maintenance

Safety Features

- comprehensive safety decal package
- conspicuity tape surrounds entire frame

High-Capacity Aluminum Fuel Tank

- reduced dry weight
- resists corrosion
- longer runs between refueling

Powerband Belt Drive

- dual five band belts
- high torque carrying capabilities

Power End Dependability

- ductile iron power frame
- largest bearings in the industry
- high-strength crankshaft

Greaseless Spread Bearing PTO

Heavy-duty bearings (spaced widely apart) and oil-bath lubrication differentiate this spread bearing PTO from the typical pilot bearing model. This field proven design offers highly reliable power transmission and reduced maintenance time. Now daily greasing is eliminated in favor of regular oil changes.

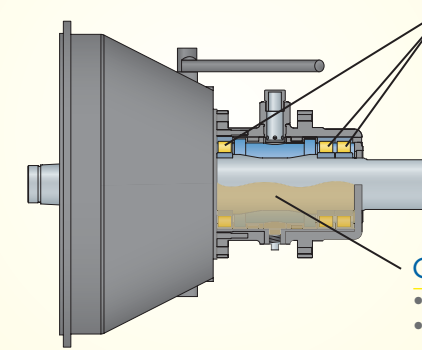

Large Spread Bearings

- opposing roller bearings provide reliable power transmission
- no pilot bearing — the "weakest link" in typical PTO's

Oil Bath Lubrication

- no daily greasing
- changed with engine oil



Shorter Wheelbase

- improves trailer travel through tight turns
- helps minimize tire scrubbing

Forward Water Tank Location

improves weight distribution with lower center of gravity

Low Profile Trailer

just 26" to top of frame for lower center of gravity

Adjustable Hitch Height

for safe, level hauling behind different vehicles

Sealed Control Panel

full instrumentation at your fingertips:

- hour meter
- tachometer
- oil pressure
- voltmeter
- water temperature

Lifetime LED Trailer Lights

- weather sealed
- corrosion resistant
- lights up faster, brighter

10-gauge Galvanized Steel Fenders

EZ-Lube Hubs

lubricate wheel bearings quickly via standard grease fitting

Safety Shutdown Systems*

protect against low oil pressure and high temperature

Torsion-Style Axles

smoother towing while providing lower trailer profile

Hydro-Throttle Control*

- saves fuel and engine wear
- manual throttle override to maintain set engine speed

Improved Pump Access

unobstructed access to fluid end for performing pressure conversion or routine maintenance

UNx™ Fluid End

Jetstream's patented system designed for fast conversion from 5,000 to 40,000 PSI operating pressures

Trailer Wiring

- completely weatherproof harness and connectors
- protective grommets runs

Center-mounted Trailer Jack

rated at 12,000 lb

Diesel Unit Options

- stationary skid
- 6,000 to 40,000 PSI conversion kits
- Safety Watch remote shutdown system
- regulator valve for shut-in applications
- electric or hydraulic brakes
- gooseneck trailer
- spare tire package
- diamond-plate protective fender tops
- workbench and industrial strength vise
- forklift pads
- powder-coated or polished aluminum wheels
- packing lube water recirculation package
- charge pump**
- engine enclosure
- air compressor package

- safety package
- fuel saving Hydro-Throttle
- special application units (i.e. oil field test pumps and hot water units)

Accessories

Jetstream carries a full line of accessories for industrial waterblasting applications. Contact Jetstream for the latest accessories catalogs.

** standard on models equipped with 40,000 PSI fluid end

Jetstream's Guardian Waterblast Filtration System™

An integrated filter and water tank design that extends component life and increases operating uptime.

It's a fact: a quality water supply is critical to waterblast pump component life. Now the Guardian Filter System helps ensure a clean water supply — even when operating conditions vary.

Within this large, rugged tank, dual filters protect your waterblast pumps and components from abrasive dirt and contaminants. These extra long filters also require fewer filter changes — allowing you more time to get the job done!

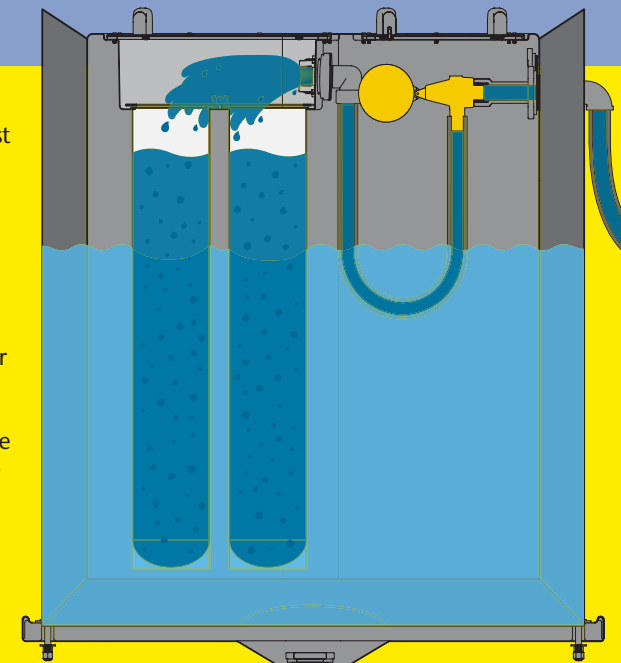

Large, 100-Gallon Tank

- large reservoir eliminates entrained air that can damage pump components
- lightweight and highly durable
- large inlet plumbing

Dual 40" Filter Bags

- 270% more filtration than standard #2 filter
- require less frequent replacement

Large Flushing Port

2" port drains entire water tank in just 90 seconds

Hinged Lid

easy access to filter bags

Low-Water Shut-Down

sealed float switch prevents pump cavitation



Protect waterblast pump components from contaminated water sources. The Guardian Filtration System is your best defense!

* optional