

Barracuda® - 20k psi

Powerful Hand-held Rotary Nozzles



Barracuda® Shotgun Nozzle

20k psi models

The **Barracuda**® sinks its teeth into tough cleaning jobs. Our leak-free seal design combined with centrifugal rotation speed control delivers more power to the surface for superior results.

The **Barracuda**® is excellent for difficult and irregular surfaces where a hand-held operator can more efficiently maneuver the cleaning head. We recommend 4-port heads for larger surface areas with thin coating removal and 2-port heads for removal of thick deposits.



- Replaceable nozzle tips
- Rotation speed control
- No air required
- 2 or 4 jet configuration
- Easy field maintenance
- Less than 3 lbs full weight
- Less maintenance than air-powered nozzles

US Patent 5,909,848 and International Patents

The **BC-K** and **BC-K-P2** both operate from 2k-20k psi and come with a 2-jet or 4-jet head configuration respectively. As with most **StoneAge**® tools, they are sold with replaceable nozzle tips.

20k psi Barracuda® Specifications

MODEL	MAX. PRES.	MAX. FLOW	LENGTH	DIAMETER	INLET	JETS
BC-K	20k psi	15 gpm	7.8 in.	1.8 in.	9/16 MP	2 x AP4
	1400 bar	57 lpm	200 mm	46 mm		
BC-K-P2	20k psi	15 gpm	7.8 in.	1.8 in.	9/16 MP	4 x AP2
	1400 bar	57 lpm	200 mm	46 mm		

Barracuda 20k psi - Jetting Chart

		NOZZLE ID in inches											
		.018	.020	.022	.024	.026	.029	.032	.035	.038	.042	.047	.052
PRESSURE in K psi	10							5.5	6.5	7.6	9.2	11.4	
	15					4.4	5.5	6.7	8.0	9.4			
	20				4.4	5.1	6.4	7.7					
	10			5.2	6.1	7.2	8.8	10.6					
	15	4.3	5.2	6.3	7.5	8.8							
	20	4.9	6.1	7.3									

Jetting Flow in gpm
2-Jet Model - BC-K
1/4 npt ports

Jetting Flow in gpm
4-Jet Model - BC-K-P2
1/8 npt ports

1-800-231-8192 • sales@waterblast.com

Jetstream of Houston, LLP • 4930 Cranswick • Houston TX 77041



© Jan '08

Barracuda® - 40k psi

Ultra-High Pressure Rotary Nozzles



40k psi Barracuda®

The **Barracuda® BC-H9-C** and **BC-H9LF-C** can handle pressures from 28k-40k psi. Both of these models feature 4 jets with speed control rotation. These self-rotary tools eliminate the need for compressed air. The **BC-H9-C** is for 4-10 gpm and the **BC-H9LF-C** is for 3-4 gpm.

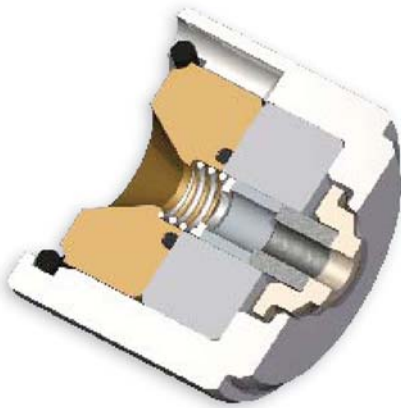

40k models feature a replaceable cartridge seal.

New Cartridge Design

Our new design features a complete replaceable cartridge unit with seat and seal for easy field maintenance. Cartridges can be replaced as complete units or components can be replaced individually.

The new system reduces down-time and improves accessibility to wear items. Now operators can have a backup cartridge on-hand which can be installed in minutes. Then the old cartridge can be field serviced and ready for re-installation when needed.

40k psi Barracuda® Specifications

MODEL	MAX. PRES.	MAX. FLOW	LENGTH	DIAMETER	INLET	JETS
BC-H9-C	40k psi	10 gpm	7.8 in.	1.8 in.	9/16 HP	4 x OS7
	2800 bar	38 lpm	200 mm	46 mm		
BC-H9LF-C	40k psi	4 gpm	7.8 in.	1.8 in.	9/16 HP	4 x OS7
	2800 bar	11 lpm	200 mm	46 mm		

Barracuda 40k psi - Jetting Chart

OS7 NOZZLE ID in inches

PRESSURE in K psi	OS7 NOZZLE ID in inches											
	.014	.015	.016	.017	.018	.019	.020	.021	.022	.023	.024	
32		3.1	3.5		3.9	4.4	4.8	5.4	5.9	6.5		
36	2.9	3.3	3.6		4.1	4.6	5.1	5.6	6.2			
40	3.0	3.5			3.8	4.3	4.8	5.4				
BC-UH-LF				BC-UH								
Jetting Flow GPM				Jetting Flow in GPM								



© Jan '08

1-800-231-8192 • sales@waterblast.com
 Jetstream of Houston, LLP • 4930 Cranswick • Houston TX 77041

SURFACE PREP

Floor Cleaners



15k or 20k psi and a 24" Jet Path

FC-TRI Floor Cleaner 3 Wheel Model

Excellent maneuverability and a simple height adjustment.



FCSV & FCSG Floor Cleaners

Available with or without vacuum system.



The **FCSV**, **FC-TRI** and **FCSG** are self-rotating, manual powered floor cleaners and surface prep machines, operating at 15k or 20k psi. The differences between the three models are that the **FCSV** comes with a 4" Camlock vacuum system while the **FCSG** and the **FC-TRI** do not. These tools are made of corrosion resistant zinc plated steel and come with a **StoneAge**® **SG-30** free spinning swivel connected to four jet arms. The swivel operates at 300 rpm-1,000 rpm from the jet reaction and uses **AP4 Attack**® **Tips**.

SURFACE PREP



Easy to hold dump lever.

Now you can clean garages, parking lots and other flat surfaces safely and effectively while eliminating operator hazard. These tools perform a wide range of functions, including cleaning paint from gratings and degreasing surfaces, as well as removing coatings decontaminates and membranes. They can also scarify concrete, clean tanks and tackle dirty pit floors. An optional vacuum attachment allows waste and debris to be removed through a standard 4" Camlock vacuum hose connection. A hand operated dump valve discharges the water pressure, as shown in the photo at left.



SG-30

Radiused arms for quality jets.

Floor Cleaner Specifications

MODEL	MAX. PRESURE	MAX. FLOW	JET PATH	HEIGHT RANGE	WEIGHT
FCSV & FCSG	15k or 20k psi	28 gpm	24 in.	1-5 in.	255 lbs
	1000 or 1400 bar	110 lpm	610 mm	30-130 mm	116 kg
FC-TRI	15k or 20k psi	28 gpm	24 in.	1-3.5 in.	341 lbs
	1000 or 1400 bar	110 lpm	610 mm	30-90 mm	155 kg

1-800-231-8192 • sales@waterblast.com
Jetstream of Houston, LLP • 4930 Cranswick • Houston TX 77041



Deck Blaster

Up to 40k psi and a 14" Jet Path



SURFACE PREP



8-Jet Bar Head

The Bar Head manifold allows up to eight **OS6 Sapphire** nozzles to be used at a time. Maximum jet path is 14".



Convenient Controls

The dump valve and rotation are controlled by lifting the lever and the forward speed is activated by a pull of the knob.

Height Adjustment

A simple adjustment allows the height to be changed quickly and easily.

40k psi Dump Valve*

Two options available.

Vacuum Recovery

A 3" vacuum attachment can pivot to either side for easy clean up.

Self Propelled Drive

The **Deck Blaster** uses air-powered speed adjustments to maximize efficiency and decrease cleaning time.

Rotation Control

The rotation speed is independently controlled and is adjustable via a valve. It operates at 250 rpm-1,000 rpm.

Spray Skirt

Deck Blaster Specifications

MODEL	MAX. PRESS.	MAX. FLOW	JET PATH	SPEED RANGE	WEIGHT	NOZZLE
DB *	40k psi	6 gpm	14 in.	3 - 20 ft/min	215 lbs	OS6
	2800 bar	20 lpm	350 mm	.9 - 6.0 m/min	116 kg	OS6

* We offer this unit with your choice of either Jetstream (JS) or Gardner Denver (GD) dump valve.



© Jan '08

1-800-231-8192 • sales@waterblast.com
 Jetstream of Houston, LLP • 4930 Cranswick • Houston TX 77041

SG-30 Free Spinners

Self-Rotating Surface Cleaners



Jet-Powered Rotation

The **SG-30 Free Spinner** tools provide a simple, self-rotating solution to surface cleaning and preparation. It uses 4 jet arms for excellent jet quality and a balanced, stable, self-rotating assembly.

It is available in either 18" or 24" jet path diameters and features a universal mounting block and replaceable **AP4 Nozzle Tips**.

Diverse Applications

StoneAge® has designed numerous systems for specialty cleaning operations. The image below shows one such application for cleaning conveyor belts. Other applications include tube skids for boiler cleaning, airport runways, belts, screens and coatings as well as degreasing and decontaminating concrete.



SG-30 Free Spinner

Radiused arms for quality jets.

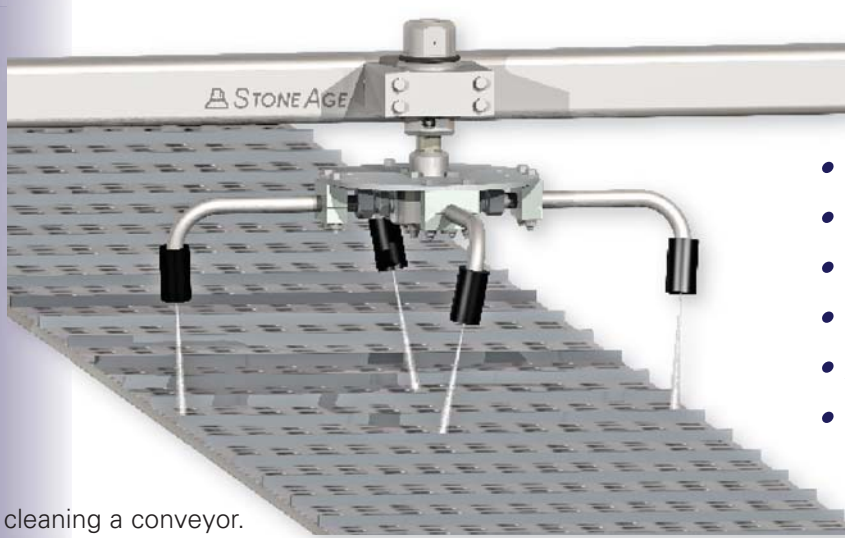

SG-30 cleaning a conveyor.

See also **BLASTRACKs** on page 11.

- **Self rotating assembly**
- **18" or 24" jet path diameter**
- **Radiused arms enhance jets**
- **Replaceable nozzle tips**
- **Aluminum mounting block**
- **Balanced, stable, rotating assembly**

Free Spinner Specifications

MODEL	MAX. PRES.	FLOW	JET PATH	ROTATION SPEED	WEIGHT	HEIGHT
SG-30-P12	15k psi	50 gpm	18 or 24 in	300-1000 rpm	25 lbs	13 in.
	1000 bar	190 lpm	460 or 620 mm	300-1000 rpm	11.3 kg	330 mm
SG-30-M12	20k psi	28 gpm	18 or 24 in	300-1000 rpm	26 lbs	13 in.
	1400 bar	110 lpm	460 or 620 mm	300-1000 rpm	11.3 kg	330 mm

1-800-231-8192 • sales@waterblast.com

Jetstream of Houston, LLP • 4930 Cranswick • Houston TX 77041



© Jan '08

SG-40, 50, 60 & 70

Hydraulic and Air-Powered Surface Cleaners



Faster Rotation SG-40 & SG-50

SG-40 Air-Powered SG-50 Hydraulic

SG 40 & 50	15k psi (1000 bar)	20k psi (1400 bar)
Swivel	SG-CCN-P12K	SG-CCN-M12K
Flow Capacity	50 gpm 190 lpm	50 gpm 190 lpm
Flow Rating	2.3 Cv	2.0 Cv
Rotation	250-1000 rpm	250-1000 rpm
Inlet Port	3/4 npt	3/4 MP*
Outlet Shaft	1-1/8 in. K**	1-1/8 in. K**
Air Sup @ 80psi	40 CFM 20 l/sec	40 CFM 20 l/sec
Hydraulic Sup.	2k psi @ 4 gpm	2k psi @ 4 gpm
Weight	26 lbs 11.8 kg	26 lbs 11.8 kg

* Medium pressure cone & thread. **1 1/8 in. OD O-ring.



Shown with optional 2-port head assembly.

The **SG-40 & SG-50** are fast rotation tools, belt driven to operate at 250 rpm-1,000 rpm. The **SG-40** uses an air motor and the **SG-50** a hydraulic motor.

SURFACE PREP

Slower Rotation SG-E60 & SG-E70

SG-60 Air-Powered SG-70 Hydraulic

SG E60 & E70	15k psi (1000 bar)	20k psi (1400 bar)
Swivel	SG-P12KM	SG-M12KM
Flow Capacity	110 gpm 420 lpm	50 gpm 190 lpm
Flow Rating	4.6 Cv	4.6 Cv
Rotation	8-40 or 35-165	8-40 or 35-165
Inlet Port	3/4 npt	3/4 MP*
Outlet Shaft	3/4 in. K**	1-1/8 in. K**
Air Sup. @ 80psi	40 CFM 20 l/sec	40 CFM 20 l/sec
Hydraulic Sup.	2k psi @ 4 gpm	2k psi @ 4 gpm
Weight	30 lbs 18.1 kg	30 lbs 18.1 kg

* Medium pressure cone & thread. **1 1/8 in. OD O-ring.



Shown with optional 2-port head assembly.

The **SG-60 & SG-70** also feature powered rotation, but at much slower speeds. The two options are 8 rpm-40 rpm, and 35 rpm-165 rpm. Slower rotation speeds increase dwell time and depth of penetration which can aid removal of thick deposits, particularly at long standoff distances. The **SG-60** is air-powered and the **SG-70** uses a hydraulic motor.



© Jan '08

1-800-231-8192 • sales@waterblast.com
Jetstream of Houston, LLP • 4930 Cranswick • Houston TX 77041

UH-40 & UH-50

40k psi Air-powered & Hydraulic Surface Cleaners



SURFACE PREP

Powered Rotation up to 40k psi

The **UH-40 & 50 Series** features the reliable **StoneAge® UH-H9G12 Swivel** and belt drive system for thorough and productive surface cleaning. Replaceable sapphire jets provide hard hitting power for epoxy coating removal or other surface preparations.

The **UH-40** uses an air motor and the **UH-50** a hydraulic drive. Additional options include a 4-arm jet assembly with up to a 20" jet path or the bar head configuration which gives a 14" jet path. Both feature a rugged, high flow design, an optional 90° inlet and use **3/8" OS6 Sapphire** nozzle tips.

- Clean belts, screens & conveyors
- Remove epoxy coatings
- Clean paint line carriers
- Prepare surfaces for coatings
- Build custom cleaning systems
- Results with minimum water flow
- Better than hand-held methods



UH-40
Air with
Bar Head

UH-50
Hydraulic
with 4 Arm
Assembly



UH-40 Air-Powered UH-50 Hydraulic	
Max. Pressure	40k psi (2800 bar)
Swivel	UH-H9G12
Flow Capacity	20 gpm 80 lpm
Flow Rating	0.50 Cv
Rotation Speed	250-1000 rpm
Inlet Port	9/16 HP*
Outlet Shaft	9/16 HP*
Air Supply @ 80psi	40 CFM 20 l/sec
Weight	26 lbs 11.8 kg

* High pressure cone & thread.



© Jan '08

Blastrack

Our Waterblast Tractor Adapts Easily



The Blastrack - Incredible Versatility

The **Blastrack** offers mechanized waterblasting with rotating jets and controlled linear motion. It features independent speed and rotation controls and is designed to work with any of our rotating assemblies shown on the previous pages. Moveable stops define the travel distance and the box rail track can be spliced to any length. With a variety of different swivels and rotary power options, the **Blastrack** can be adapted to almost any application.

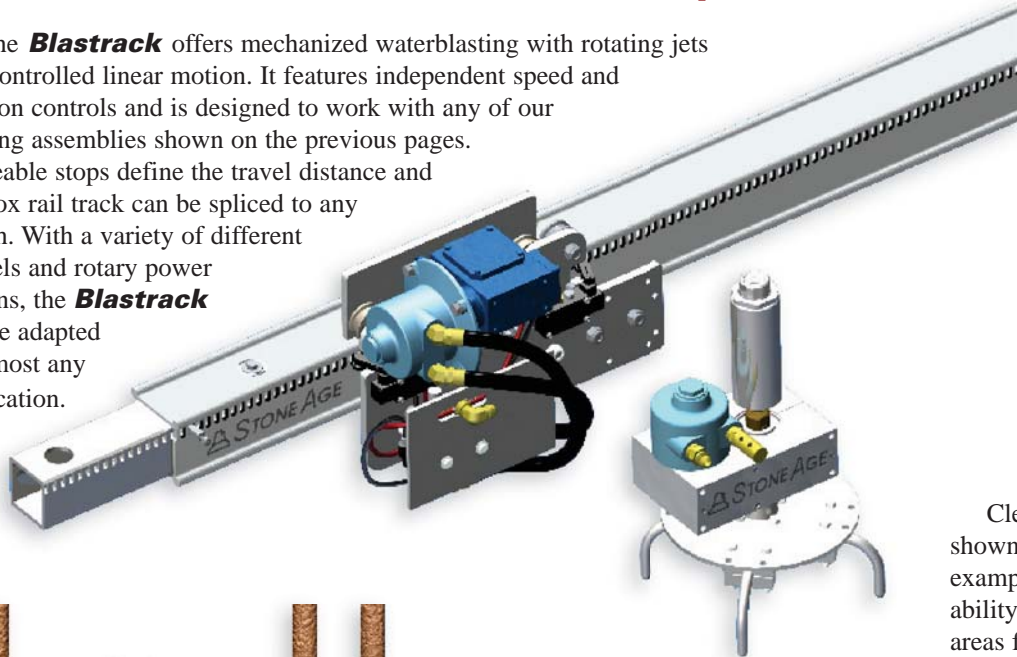

Cleaning fan blades, shown below, is a perfect example of **Blastrack's** ability to access hard to reach areas for routine cleaning.



The **Blastrack** can be outfitted with 2 rotating jet heads in opposing directions for slot cleaning in between two surfaces, as shown at left.

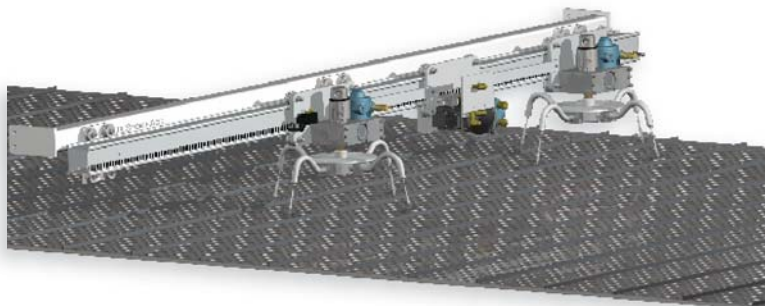
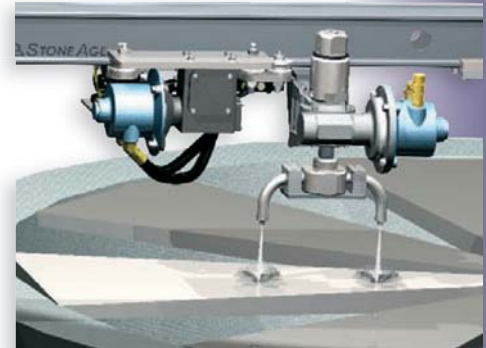

The **Blastrack** can handle grates and surfaces (both horizontal and vertical) with ease. The example above shows 2 SG-40's operating in tandem along one rail to clean this conveyor.

Blastrack Specs

Blastrack	BUD-100
Max. Pressure	15k - 40k psi 1000 - 2800 bar
Max. Flow	110 gpm 420 lpm
Rotation	Up to 1000 rpm
Linear Speed	7-40 ft/min

Contact us for the best components to suit your application.



1-800-231-8192 • sales@waterblast.com
Jetstream of Houston, LLP • 4930 Cranswick • Houston TX 77041